

Kit Leaflet

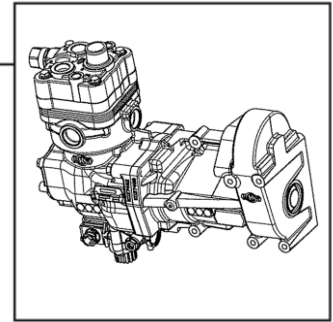

K052056K50
Clutch housing kit
Kupplungsgehäuse Satz

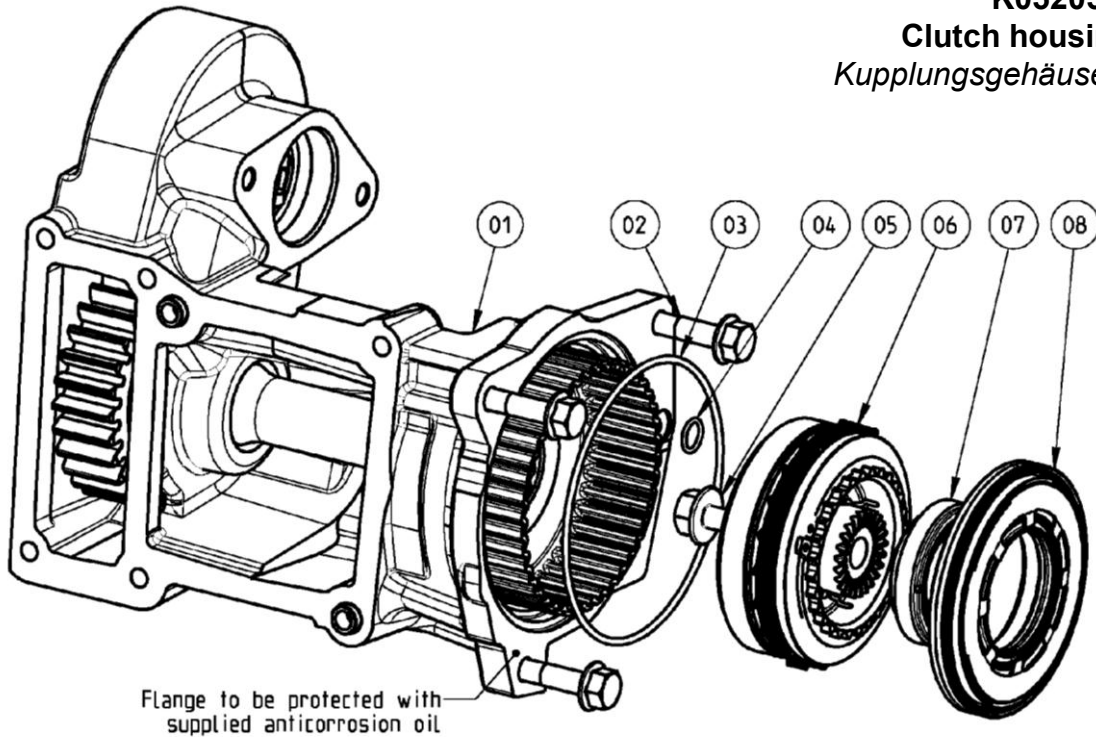

Pos.	Description	Qty.			
01	Clutch housing assy	1	07	Ball bearing	1
02	Housing screw (50Nm)	3	08	Clutch driving piston	1
03	O-ring	1	-	Anticorrosion oil sample	1
04	O-ring	1			
05	Clutch screw (15Nm+60°)	1			
06	Clutch pack	1			



Y075876

Safety and Environment Guidelines / Sicherheits- und Umweltrichtlinie

www.knorr-bremseCVS.com



K061416 A4 80 a/m² white